

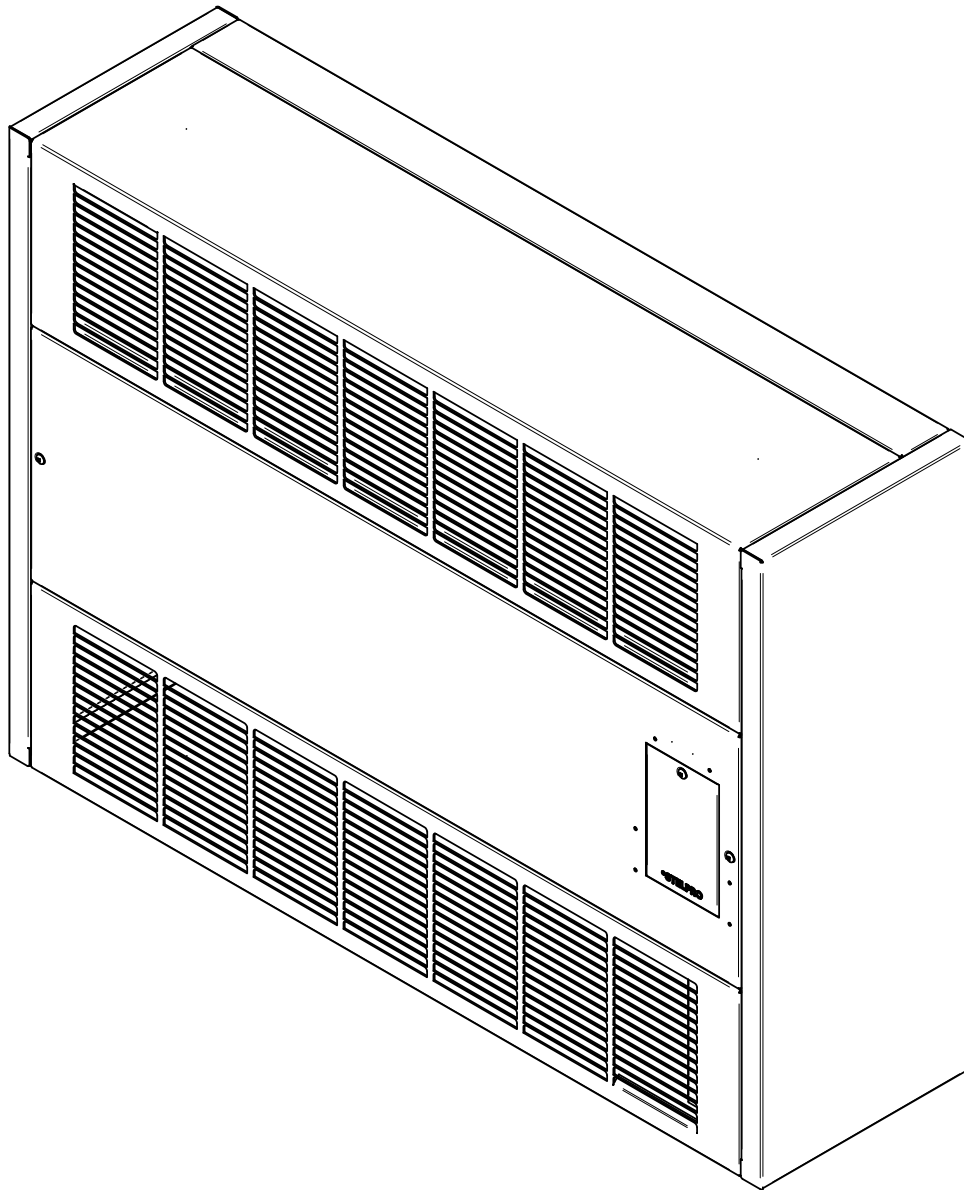

USER'S GUIDE

CBH SERIES CABINET HEATER

REPLACEMENT COMPONENT LIST INCLUDED



This unit
complies
with CSA
standards





WARNING

Before installing and operating this product, the user and/or installer must read, understand and follow these instructions and keep them handy for future reference. If these instructions are not followed, the warranty will be considered null and void and the manufacturer deems no further responsibility for this product.

This product must be installed by a qualified person and connected by a **certified electrician**, according to the **electrical and building codes** effective in your region.

The following instructions must be adhered to in order to avoid personal and serious injuries, property damages and potentially fatal electric shocks.

Protect the heating unit with the appropriate circuit breaker or fuse, in accordance with the nameplate.

Make sure the line voltage (volt) is consistent with that indicated on the unit's nameplate.

This unit must be **grounded**.

Switch off the power at the circuit breaker/fuse before installing, repairing and cleaning the unit.

Make sure the unit is appropriate for the intended use (if needed, refer to the product catalog or a representative).

RECOMMENDED HEATING CAPACITY:

1.25 W/cubic foot (0.03 m³)

It corresponds to **10 W/square foot (0.09 m²)** based on a standard ceiling height of 8 feet (2.44 m). The recommended capacity is usually sufficient for normal heating needs. Please note that the insulation quality of walls and windows are some of the factors that influence heat loss, which modify the required capacity to heat a room. If needed, refer to a specialist (industrial and commercial buildings) who will be able to calculate these heat losses and optimize the required capacity or consult the "Tools/Heating Calculator" section of the Stelpro Design website (residential buildings).

Do not install the unit where objects or pieces of furniture could be damaged by heat.

If the unit capacity is insufficient for the size of the room, it will be in operation continuously, and may become defective earlier and turn yellow.

Respect distances and positions indicated in the installation section.

If the installer or the user modifies the unit, he will be held responsible for any damage resulting from this modification, and the CSA certification could be void.

This unit must not come into contact with a water source and must be protected from splashes (e.g. a wet mop). Do not use it if any part has been immersed. Moreover, do not turn it on or off when standing in water or if your hands are wet.

When starting up the unit for the first time or after a long period, it is normal that it produce some temporary odours and a whitish smoke.

Because this unit is hot when in use, it may pose risks even in normal operation. Therefore, be careful and responsible when using it. To avoid burns, do not touch hot surfaces with bare skin. Allow the unit to cool down for a few minutes since it stays warm for some time after shut-down.

Make sure objects or pieces of furniture do not come into contact with the unit and keep them at least **12 inches (30.5 cm)** from it. Failure to comply with this warning could result in a fire. Some materials are more heat-sensitive than others, so make sure those near the unit can withstand heat.

Do not install on a wall behind a door.

Never block unit air vents. This obstruction could lead to overheating, which could result in a fire.

Do not insert or allow foreign objects to enter the air vent as this may cause electric shocks, fires, or damages to the unit.

This unit has hot and arcing or sparking parts inside. It is not designed to be used or stored in wet areas or areas containing flammable liquids, combustible materials or corrosive, abrasive, chemical, explosive and flammable substances such as, but not limited to, gasoline, paint, chlorine, sawdust and cleaning products.

Some areas are dustier than others. Thus, it is the user's responsibility to evaluate if the unit **must be cleaned** based on the amount of dirt accumulated on and inside air vents. Accumulated dirt can lead to a component malfunction or give a yellowish colour to unit. Failure to install and maintain unit in accordance with these instructions poses a fire hazard.

The thermal protection activation indicates that the unit has been subjected to abnormal operating conditions. If the thermal protection remains activated or activates and deactivates repeatedly, it is recommended that a qualified electrician or a certified repair centre examine the unit in order to make sure it is not damaged. (Refer to the limited warranty)

If the unit is damaged or defective, cut off power supply at circuit breaker and call a certified repair centre. (Refer to the limited warranty)

Make sure that all the electrical connections are secure and have been made properly. Pull each wire to ensure it is not loose in the connector or the terminal board as this may cause a fire.

If an option must be added, make sure it has been approved by Stelpro. This way, it will ensure that it has been tested in accordance with our safety rules and that an appropriate installation has been planned into the unit.

Do not use optional 0-100% AIR DAMPER with bottom air inlet.

Do not install air inlet to a heating or cooling system.



Note: When a part of the product specification must be changed to improve operability or other functions, priority is given to the product specification itself. In such instances, the instruction manual may not entirely match all the functions of the actual product. Therefore, the actual product and packaging, as well as the name and illustration, may differ from the manual.

TECHNICAL DRAWINGS

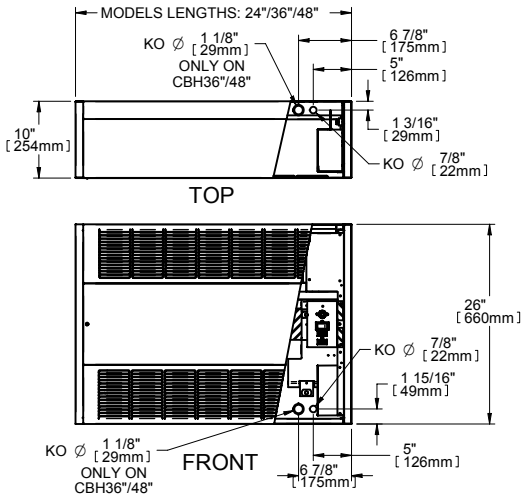

SPECIFICATIONS

CONTACT SWITCH	CONTACT SWITCH & BUILT-IN THER.	24 V CONTROL	HIGH DENSITY	CFM	VOLTS	PH.	KG	LB
CBH02X1C	CBH02X1CT	CBH02X1C24	2000 W	300	X	1	34.9	77
CBH03X1C	CBH03X1CT	CBH03X1C24	3000 W	300	X	1	34.9	77
CBH04X1C	CBH04X1CT	CBH04X1C24	4000 W	300	X	1	34.9	77
CBH05X1C	CBH05X1CT	CBH05X1C24	5000 W	300	X	1	34.9	77
CBH06X1C	CBH06X1CT	CBH06X1C24	6000 W	300	X	1	34.9	77
CBH08X1C	CBH08X1CT	CBH08X1C24	8000 W	600	X	1	43	95
CBH10X1C	CBH10X1CT	CBH10X1C24	10000 W	600	X	1	43	95
CBH12X3C	CBH12X3CT	CBH12X3C24	12000 W	600	X	3	43	95
CBH15X3C	CBH15X3CT	CBH15X3C24	15000 W	1000	X	3	50.7	112
CBH18X3C	CBH18X3CT	CBH18X3C24	18000 W	1000	X	3	50.7	112
CBH20X3C	CBH20X3CT	CBH20X3C24	20000 W	1000	X	3	50.7	112

Add **W** for white or **SW** for soft almond

x = 8 (208 V) 2 (240 V) 7 (277 V) 3 (347 V) 5 (480 V) 6 (600 V)

INSTALLATION



Cut off power supply at circuit breaker/fuse before proceeding with installation.

N.B. This product must be installed by a qualified and certified electrician, according to the electrical and building codes effective in your region.

1. Do not install the unit under a wall outlet.
2. To install accessories (a thermostat), please refer to their respective installation guides.

HOW TO CHANGE AIR FLOW DIRECTION

Designed with reversible grills, the CBH can be installed with any air flow direction you desire.

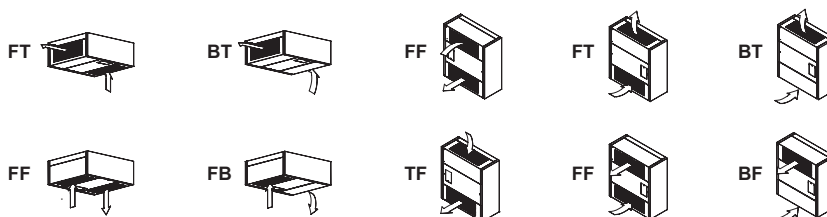
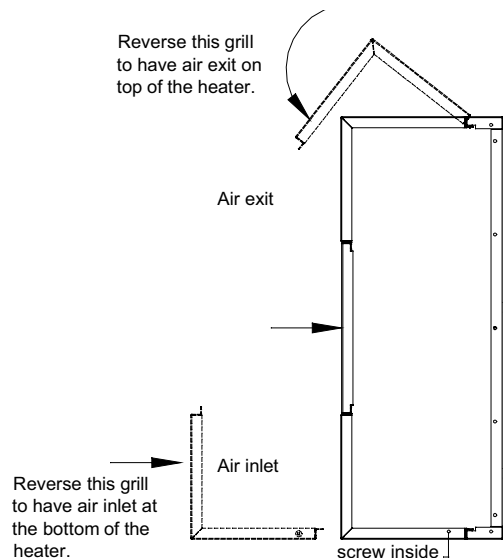

Several airflow configurations are possible and adaptable on-the-spot

F = FRONT
T = TOP
B = BOTTOM

1. Remove the 2 screws on the middle panel, and the 2 screws in the grill.
2. Position the grill as you wish.

NOTE: Since the air exit grill is protected by another grill, it must be installed at the air exit.

CONTROLS

- Built-in tamper proof thermostat (optional)
- On/Off switch (optional)
- Continuous fan switch (optional)
- Hi/Lo speed/heat power selector switch (optional)

Note: The Hi/Lo option is only available from 4kW

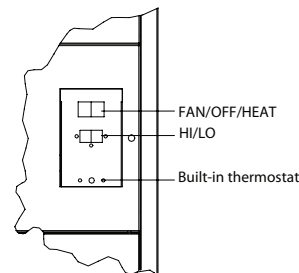

WALL OR CEILING INSTALLATION

For a ceiling installation you need 4 rods (1/2-13nc). The length of the rods depends on the height you want the model placed from the ceiling. Stelpro recommends 8' from the floor for units of 6000 W and less and 12' for units of 8000 W and more. Units with BT and BF air inlets and outlets must be installed at least 8' from the floor also (see previous page for modifications). See the diagram for the distance between fixing holes. For wall installation, 4 screws (3/8-16nc) are needed.

NOTE: A nut should be placed on the threaded rod behind the heater to lock the assembly in place.

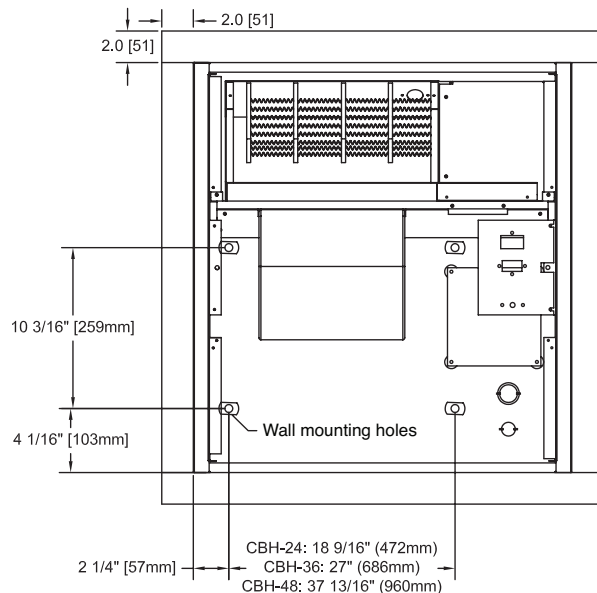

OPTIONS

The CBH can be installed on a wall or a ceiling, surface mounted, recessed or semi-recessed with a 4-piece frame.

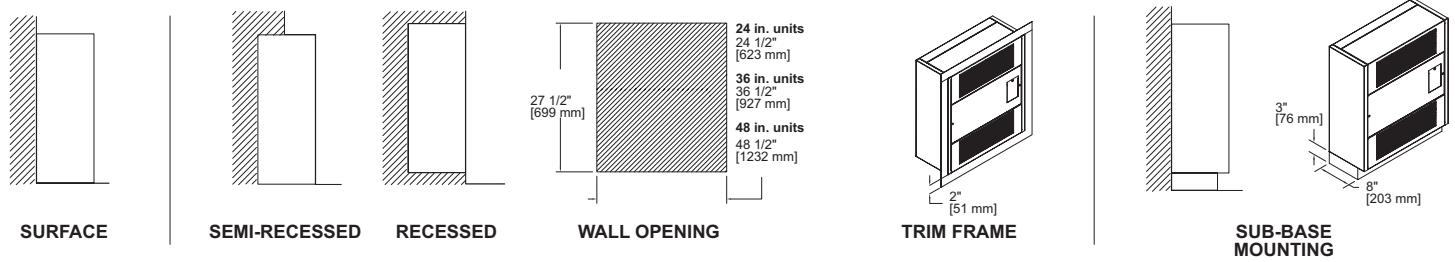

DIFFERENT OPTIONS ARE OFFERED DEPENDING ON THE APPLICATION:

SUB-BASE (SB) Floor installation:

- Anchor the sub base to the floor using the holes provided.
- Make the electrical connections.
- Install the heater on the sub base with the self-tapping screws provided.

CLEAN BACK (CB) The clean back is installed with self-tapping screws from the inside of the casing. We recommend a 6-inch spacing between each screw.

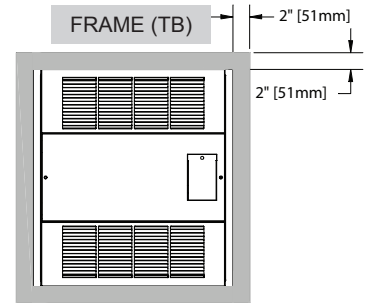

OPTIONAL 100% OUTSIDE AIR DAMPER

- See figure X for location of damper opening.
- Position field ductwork to outside of flange bracket.
- Mark and drill starting holes in duct and flange.
- Install and tighten screws (filed supplied) to provide a secure seal.

Operation of 100% outside air damper

- Opening (if motorized option is installed) will open up when the unit will start heating.

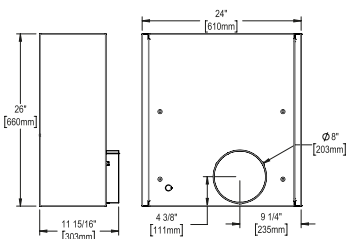

CBHR24

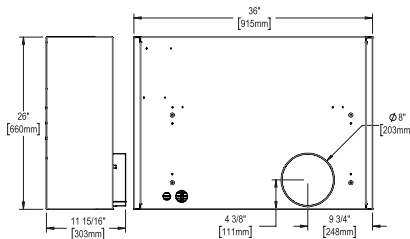

CBHR36

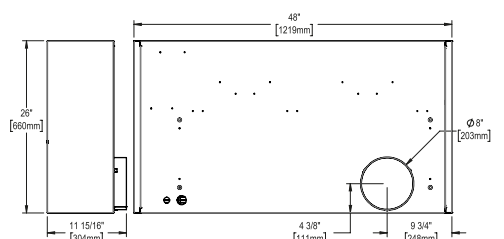

CBHR48

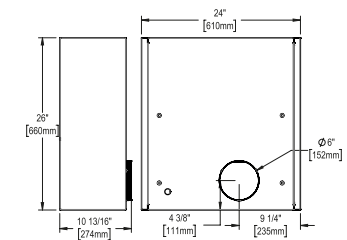

CBHR24M

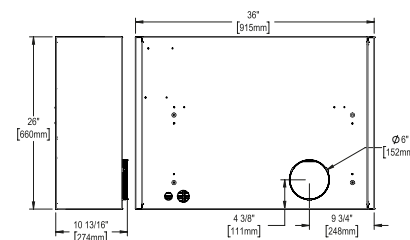

CBHR36M

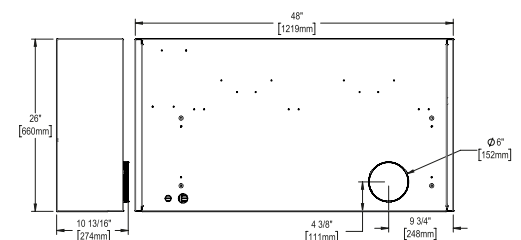

CBHR48M

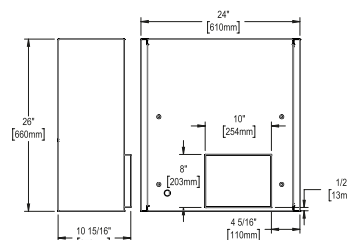

CBHS24

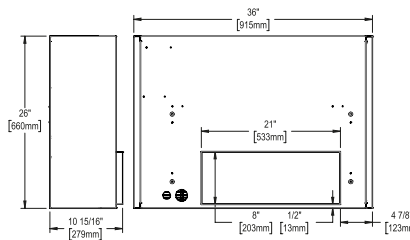

CBHS36

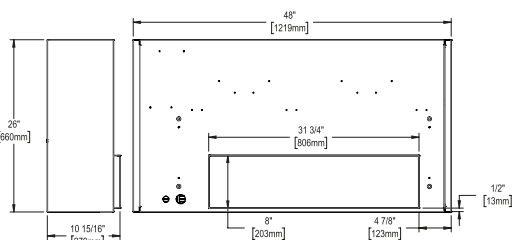

CBHS48

ELECTRICAL WIRING

This unit should be installed by a certified electrician. Cut off power supply at circuit breaker. Make the electrical connections and the ground according to the standards of Electric Code(s) in place in your region. If you are not familiar with those codes, you must contact a qualified electrician. The connexion diagrams can be found at the back of the central panel. For units with FAN/OFF/HEAT and Hi/Lo switches or built-in thermostat, the access door is located on the right side of the central panel. A screw must be removed to have access.

MAINTENANCE



N.B. In order for the warranty to be valid, the unit must be cleaned regularly.

Cut off power supply at circuit breaker/fuse before cleaning the unit. Use a soft rag for dusting. When cleaning, use only a damp rag and non-abrasive dish soap. Do not use abrasive or chemical cleaners because they may damage the finishing. If the unit is used in a very dusty location, use a vacuum brush to remove dust and other foreign objects from the grilles. Note that cigarette smoke could yellow the discharge grille and that the best way to prevent it is to clean the unit on a regular basis.

Do not use cleaning products identified with these symbols:



N.B. Note that there is electrical current to the unit even if the thermostat is off. Meaning that there is a risk of electric shock as long as the unit is energized.

REPLACEMENT COMPONENT LIST

REF #	PART #	DESCRIPTION	REF #	PART #	DESCRIPTION	REF #	PART #	DESCRIPTION
1	BLO-001	BLOWER WHEEL	11	FS-005	FUSE 15A CLASS CC 600V T.D.	16	ELF-CBH0353	ELEMENT (KIT) 3KW 480V 3PH
2	BLO-002	HOUSING FOR BLOWER WHEEL	11	FS-016	FUSE 40A CLASS J 600V T.D.	16	ELF-CBH0361	ELEMENT (KIT) 3KW 600V 1PH
3	BOUT-003	THERMOSTAT KNOB (BLACK)	11	FS-018	FUSE 60A CLASS J 600V T.D.	16	ELF-CBH0363	ELEMENT (KIT) 3KW 600V 3PH
4	R841D1036	RELAY WITHOUT TRANSFORMER-24V	11	FS-026	FUSE 35A CLASS J 600V T.D.	16	ELF-CBH0371	ELEMENT (KIT) 3KW 277V 1PH
4	R841C1169	RELAY 208/240-24V	12	HOLD-005	FUSE HOLDER 2 POLES 600V	16	ELF-CBH0381	ELEMENT (KIT) 3KW 208V 1PH
5	CONT-3002	CONTACTOR 30A 2 POLES 24V	12	HOLD-009	FUSE HOLDER 1 POLE 600V	16	ELF-CBH0383	ELEMENT (KIT) 3KW 208V 3PH
5	CONT-3022	CONTACTOR 30A 2 POLES 240-208V	12	HOLD-010	FUSE HOLDER 2 POLES 600V	16	ELF-CBH0421	ELEMENT (KIT) 4KW 240V 1PH
5	CONT-3503	CONTACTOR 35A 3 POLES 24V	12	HOLD-011	FUSE HOLDER 3 POLES 600V	16	ELF-CBH0431	ELEMENT (KIT) 4KW 347V 1PH
5	CONT-4023	CONTACTOR 40A 3 POLES 240-208V	13	M-CBH2400B*	UPPER GRILL (CBH24")	16	ELF-CBH0451	ELEMENT (KIT) 4KW 480V 1PH
5	CONT-5023	CONTACTOR 50A 3 POLES 240-208V	13	M-CBH3600B*	UPPER GRILL (CBH36")	16	ELF-CBH0453	ELEMENT (KIT) 4KW 480V 3PH
6	MO-025	MOTOR 1/15HP 208/240V (2-12KW)	13	M-CBH4800B*	UPPER GRILL (CBH48")	16	ELF-CBH0461	ELEMENT (KIT) 4KW 600V 1PH
6	MO-026-2	MOTOR 1/5HP 208/240V (15-20KW)	14	M-CBH2451Z*	FRONT PANNEL (CBH24")	16	ELF-CBH0463	ELEMENT (KIT) 4KW 600V 3PH
7	PROT-006	THERMAL PROTECTION (AUTO.) (L150)	14	M-CBH3651Z*	FRONT PANNEL (CBH36")	16	ELF-CBH0471	ELEMENT (KIT) 4KW 277V 1PH
7	PROT-011	FAN DELAY (F110) (4-20KW)	14	M-CBH4851Z*	FRONT PANNEL (CBH48")	16	ELF-CBH0481	ELEMENT (KIT) 4KW 208V 1PH
8	ST-001	THERMOSTAT SP (BULB TYPE)	15	M-CBH2400C*	LOWER GRILL (CBH24")	16	ELF-CBH0483	ELEMENT (KIT) 4KW 208V 3PH
8	ST-012	THERMOSTAT DP (BULB TYPE)	15	M-CBH3600C*	LOWER GRILL (CBH36")	16	ELF-CBH0521	ELEMENT (KIT) 5KW 240V 1PH
9	SWI-002	HI / LOW SWITCH (DPDT)	15	M-CBH4800C*	LOWER GRILL (CBH48")	16	ELF-CBH0531	ELEMENT (KIT) 5KW 347V 1PH
9	SWI-006	SWITCH (SPDT)	16	ELF-CBH0351	ELEMENT (KIT) 3KW 480V 1PH	16	ELF-CBH0551	ELEMENT (KIT) 5KW 480V 1PH
10	TRF200025	TRANSFORMER 240/24/25VA	16	ELF-CBH0331	ELEMENT (KIT) 3KW 347V 1PH	16	ELF-CBH0553	ELEMENT (KIT) 5KW 480V 3PH
10	TRF300025	TRANSFORMER 347/24/25VA	16	ELF-CBH0251	ELEMENT (KIT) 2KW 480V 1PH	16	ELF-CBH0561	ELEMENT (KIT) 5KW 600V 1PH
10	TRF320250	TRANSFORMER 347/240/250VA	16	ELF-CBH0321	ELEMENT (KIT) 3KW 240V 1PH	16	ELF-CBH0563	ELEMENT (KIT) 5KW 600V 3PH
10	TRF500025D	TRANSFORMER 240-480/12-24/25VA	16	ELF-CBH0283	ELEMENT (KIT) 2KW 208V 3PH	16	ELF-CBH0571	ELEMENT (KIT) 5KW 277V 1PH
10	TRF510350D	TRANSFORMER 240-480/120-240/350VA	16	ELF-CBH0281	ELEMENT (KIT) 2KW 208V 1PH	16	ELF-CBH0581	ELEMENT (KIT) 5KW 208V 1PH
10	TRF600025	TRANSFORMER 600/24/25VA	16	ELF-CBH0271	ELEMENT (KIT) 2KW 277V 1PH	16	ELF-CBH0583	ELEMENT (KIT) 5KW 208V 3PH
10	TRF620250	TRANSFORMER 600/240/250VA	16	ELF-CBH0263	ELEMENT (KIT) 2KW 600V 3PH	16	ELF-CBH0621	ELEMENT (KIT) 6KW 240V 1PH
10	TRF700025	TRANSFORMER 277/24/25VA	16	ELF-CBH0261	ELEMENT (KIT) 2KW 600V 1PH	16	ELF-CBH0631	ELEMENT (KIT) 6KW 347V 1PH
10	TRF720250	TRANSFORMER 277/240/250VA	16	ELF-CBH0253	ELEMENT (KIT) 2KW 480V 3PH	16	ELF-CBH0651	ELEMENT (KIT) 6KW 480V 1PH
10	TRF200040D	TRANSFORMER 208-240/24/40VA, CL.2 CL.B	16	ELF-CBH0221	ELEMENT (KIT) 2KW 240V 1PH	16	ELF-CBH0653	ELEMENT (KIT) 6KW 480V 3PH
10	TRF810350D	TRANSFORMER 208-416/120-240/350VA	16	ELF-CBH0231	ELEMENT (KIT) 2KW 347V 1PH	16	ELF-CBH0661	ELEMENT (KIT) 6KW 600V 1PH

*Add **W** for white or **SW** for soft white

REF #	PART #	DESCRIPTION
16	ELF-CBH0663	ELEMENT (KIT) 6KW 600V 3PH
16	ELF-CBH0671	ELEMENT (KIT) 6KW 277V 1PH
16	ELF-CBH0681	ELEMENT (KIT) 6KW 208V 1PH
16	ELF-CBH0683	ELEMENT (KIT) 6KW 208V 3PH
16	ELF-CBH0821	ELEMENT (KIT) 8KW 240V 1PH
16	ELF-CBH0831	ELEMENT (KIT) 8KW 347V 1PH
16	ELF-CBH0851	ELEMENT (KIT) 8KW 480V 1PH
16	ELF-CBH0853	ELEMENT (KIT) 8KW 480V 3PH
16	ELF-CBH0861	ELEMENT (KIT) 8KW 600V 1PH
16	ELF-CBH0863	ELEMENT (KIT) 8KW 600V 3PH
16	ELF-CBH0871	ELEMENT (KIT) 8KW 277V 1PH
16	ELF-CBH0881	ELEMENT (KIT) 8KW 208V 1PH
16	ELF-CBH0883	ELEMENT (KIT) 8KW 208V 3PH
16	ELF-CBH1021	ELEMENT (KIT) 10KW 240V 1PH
16	ELF-CBH1031	ELEMENT (KIT) 10KW 347V 1PH
16	ELF-CBH1051	ELEMENT (KIT) 10KW 480V 1PH
16	ELF-CBH1053	ELEMENT (KIT) 10KW 480V 3PH
16	ELF-CBH1061	ELEMENT (KIT) 10KW 600V 1PH

REF #	PART #	DESCRIPTION
16	ELF-CBH1063	ELEMENT (KIT) 10KW 600V 3PH
16	ELF-CBH1071	ELEMENT (KIT) 10KW 277V 1PH
16	ELF-CBH1081	ELEMENT (KIT) 10KW 208V 1PH
16	ELF-CBH1083	ELEMENT (KIT) 10KW 208V 3PH
16	ELF-CBH1221	ELEMENT (KIT) 12KW 240V 1PH
16	ELF-CBH1231	ELEMENT (KIT) 12KW 347V 1PH
16	ELF-CBH1253	ELEMENT (KIT) 12KW 480V 3PH
16	ELF-CBH1263	ELEMENT (KIT) 12KW 600V 3PH
16	ELF-CBH1271	ELEMENT (KIT) 12KW 277V 1PH
16	ELF-CBH1283	ELEMENT (KIT) 12KW 208V 3PH
16	ELF-CBH1521	ELEMENT (KIT) 15KW 240V 1PH
16	ELF-CBH1531	ELEMENT (KIT) 15KW 347V 1PH
16	ELF-CBH1553	ELEMENT (KIT) 15KW 480V 3PH
16	ELF-CBH1563	ELEMENT (KIT) 15KW 600V 3PH
16	ELF-CBH1571	ELEMENT (KIT) 15KW 277V 1PH
16	ELF-CBH1583	ELEMENT (KIT) 15KW 208V 3PH
16	ELF-CBH1821	ELEMENT (KIT) 18KW 240V 1PH
16	ELF-CBH1831	ELEMENT (KIT) 18KW 347V 1PH

REF #	PART #	DESCRIPTION
16	ELF-CBH1853	ELEMENT (KIT) 18KW 480V 3PH
16	ELF-CBH1863	ELEMENT (KIT) 18KW 600V 3PH
16	ELF-CBH1871	ELEMENT (KIT) 18KW 277V 1PH
16	ELF-CBH1883	ELEMENT (KIT) 18KW 208V 3PH
16	ELF-CBH2021	ELEMENT (KIT) 20KW 240V 1PH
16	ELF-CBH2031	ELEMENT (KIT) 20KW 347V 1PH
16	ELF-CBH2053	ELEMENT (KIT) 20KW 480V 3PH
16	ELF-CBH2063	ELEMENT (KIT) 20KW 600V 3PH
16	ELF-CBH2071	ELEMENT (KIT) 20KW 277V 1PH
16	ELF-CBH2083	ELEMENT (KIT) 20KW 208V 3PH
--	BDD-016M	MOTORIZED DAMPER 4" DIAM 24 V
--	BDD-017M	MOTORIZED DAMPER 5" DIAM 24 V
--	BDD-018M	MOTORIZED DAMPER 6" DIAM 24 V
--	FILTRE-002	WASHABLE ALUMINUM FILTER 9 X 11-1/2 X 1/2
--	FILTRE-003	WASHABLE ALUMINUM FILTER 9 X 22-1/2 X 1/2
--	FILTRE-004	WASHABLE ALUMINUM FILTER 9 X 34-1/4 X 1/2

*Add **W** for white or **SW** for soft white

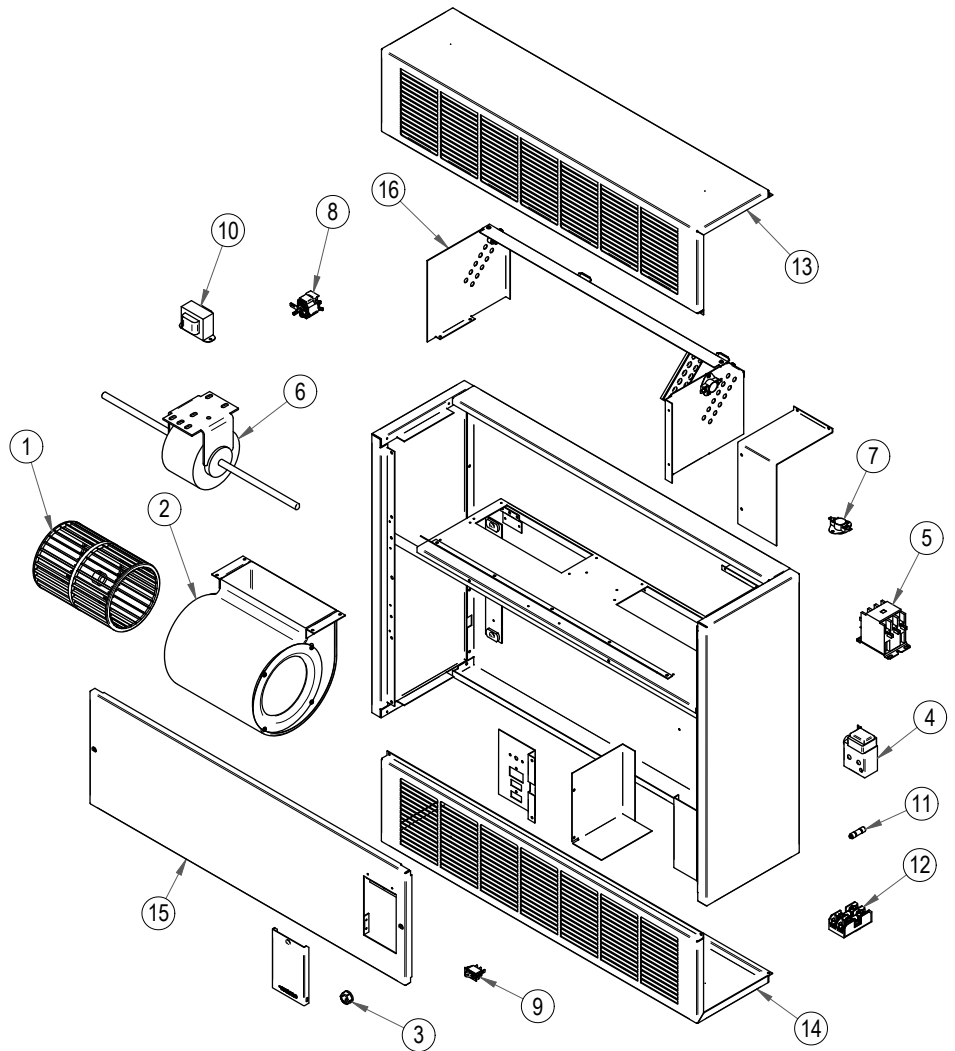

TROUBLESHOOTING

PROBLEM	DEFECTIVE PART OR PART TO CHECK
The unit does not work	<ul style="list-style-type: none"> - Defective thermostat or wrong thermostat setting - Open circuit breaker or fuse - Thermal protection activated - Faulty connections
The unit runs continuously	<ul style="list-style-type: none"> - Defective thermostat or wrong thermostat setting - Heat losses greater than the unit's capacity
The enclosure is extremely hot	<ul style="list-style-type: none"> - Defective thermal protection - Blocked air vents
The desired room temperature cannot be reached	<ul style="list-style-type: none"> - One or more defective elements - Defective thermostat or wrong thermostat setting - Voltage lower than that indicated on the nameplate - Heat losses greater than the unit's capacity
Overheating	<ul style="list-style-type: none"> - Defective thermostat or wrong thermostat setting
The unit cycles under control of the thermal protection (overheat indicator)	<ul style="list-style-type: none"> - Blocked air vents
The breaker trips when the heater is turned on	<ul style="list-style-type: none"> - Faulty connections - Voltage greater than that indicated on the nameplate

N.B. If you do not solve the problem after checking these points, cut off the power supply at the main electrical panel and contact our customer service (see the "Limited warranty" section to obtain the phone numbers).

LIMITED WARRANTY

This limited warranty is offered by Stelpro Design inc. ("Stelpro") and applies to the following product made by Stelpro: CBH model. **Please read this limited warranty carefully.** Subject to the terms of this warranty, Stelpro warrants its products and their components against defects in workmanship and/or materials for the following periods from the date of purchase: **3 years.** This warranty applies only to the original purchaser; it is non-transferable and cannot be extended.

CLAIM PROCEDURE

If at any time during the warranty period the unit becomes defective, you must cut off the power supply at the main electrical panel and contact 1) your installer or distributor, 2) your service center or 3) Stelpro's customer service department. In all cases, you must have a **copy of the invoice** and provide the **information written on the product nameplate.** Stelpro reserves the right to examine or to ask one of its representatives to examine the product itself or any part of it before honoring the warranty. Stelpro reserves the right to replace the entire unit, refund its purchase price or repair a defective part. Please note that repairs made within the warranty period must be authorized in advance in writing by Stelpro and carried out by persons authorized by Stelpro.

Before returning a product to Stelpro, you must have a Stelpro authorization number (RMA). To obtain it, call the customer service department at: **1-800-363-3414** (electricians and distributors - French), **1-800-343-1022** (electricians and distributors - English), or **1-866-766-6020** (consumers). The authorization number must be clearly written on the parcel or it will be refused.

CONDITIONS, EXCLUSIONS AND DISCLAIMER OF LIABILITY

This warranty is exclusive and in lieu of all other representations and warranties (except of title), expressed or implied, and Stelpro expressly disclaims and excludes any implied warranty of merchantability or implied warranty of fitness for a particular purpose.

Stelpro's liability with respect to products is limited as provided above. Stelpro shall not be subject to any other obligations or liabilities whatsoever, whether based on contract, tort or other theories of law, with respect to goods or services furnished by it, or any undertakings, acts or omissions relating thereto. Without limiting the generality of the foregoing, Stelpro expressly disclaims any liability for property or personal injury damages, penalties, special or punitive damages, damages for lost profits, loss of use of equipment, cost of capital, cost of substitute products, facilities or services, shutdowns, slowdowns, or for other types of economic loss or for claims of a dealer's customers or any third party for such damages. Stelpro specifically disclaims all consequential, incidental and contingent damages whatsoever.

This warranty does not cover any damages or failures resulting from: 1) a faulty installation or improper storage; 2) an abusive or abnormal use, lack of maintenance, improper maintenance (other than that prescribed by Stelpro) or a use other than that for which the unit was designed; 3) a natural disaster or an event out of Stelpro's control, including, but not limited to, hurricanes, tornadoes, earthquakes, terrorist attacks, wars, overvoltage, flooding, water damages, etc. This warranty does not cover any accidental or intentional losses or damages, nor does it cover damages caused by negligence of the user or owner of the product. Moreover, it does not cover the cost of disconnection, transport, and installation.

The warranty is limited to the repair or the replacement of the unit or the refund of its purchase price, **at the discretion of Stelpro.** Any parts replaced or repaired within the warranty period with the written authorization of Stelpro will be warranted for the remainder of the original warranty period. This warranty will be considered null and void and Stelpro will have the right to refuse any claims if **products have been altered** without the written authorization of Stelpro and if the nameplate numbers have been removed or modified. This warranty does not cover scratches, dents, corrosion or discoloration caused by excessive heat, chemical cleaning products and abrasive agents. It does not cover any damage that occurred during the shipping.

Some states and provinces do not allow the exclusion or limitation of incidental or consequential damages and some of them do not allow limitations on how long an implied warranty lasts, so these exclusions or limitations may not apply to you. This warranty gives you specific legal rights and you may have other rights which vary from state to state or from province to province.