

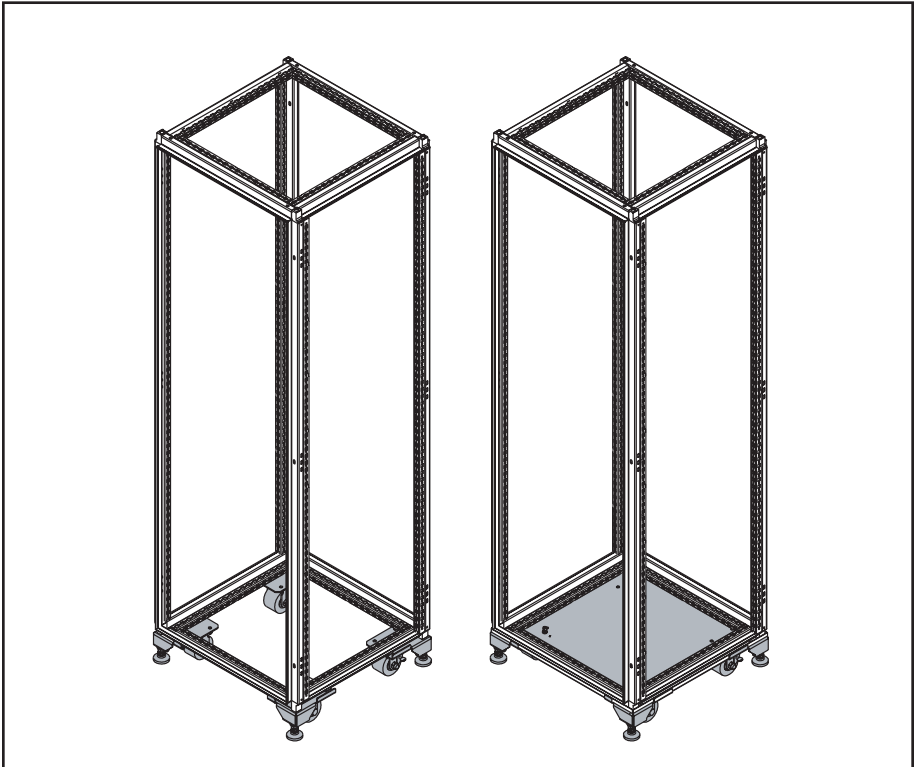

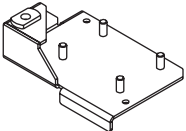

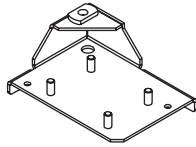
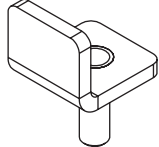

HOFFMAN

ProLine S1

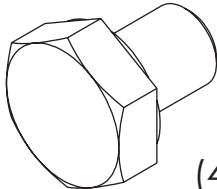
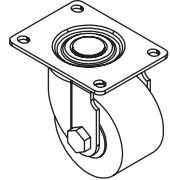

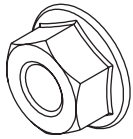
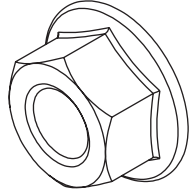
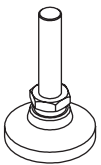
<p>1</p>  <p>(2X)</p>	<p>2</p>  <p>(2X)</p>	<p>3</p>  <p>(8X)</p>
<p>4</p>  <p>(8X)</p>	<p>5</p>  <p>(4X)</p>	<p>6</p>  <p>(4X)</p>
<p>7</p>  <p>(16X)</p>	<p>8</p>  <p>(16X)</p>	<p>9</p>  <p>(4X)</p>
<p>10</p>  <p>(4X)</p>		

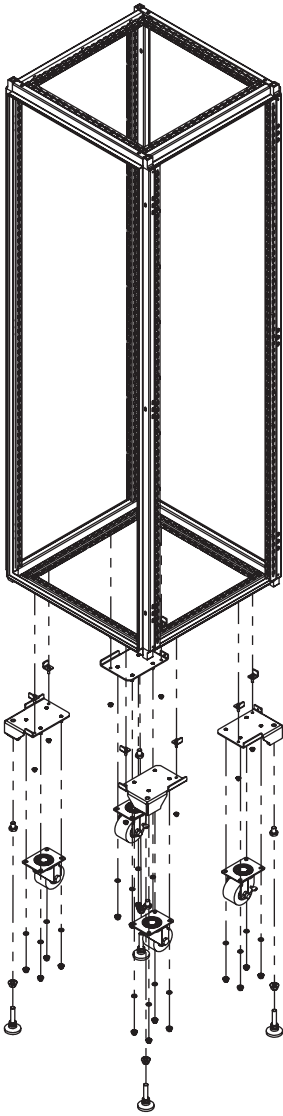

A

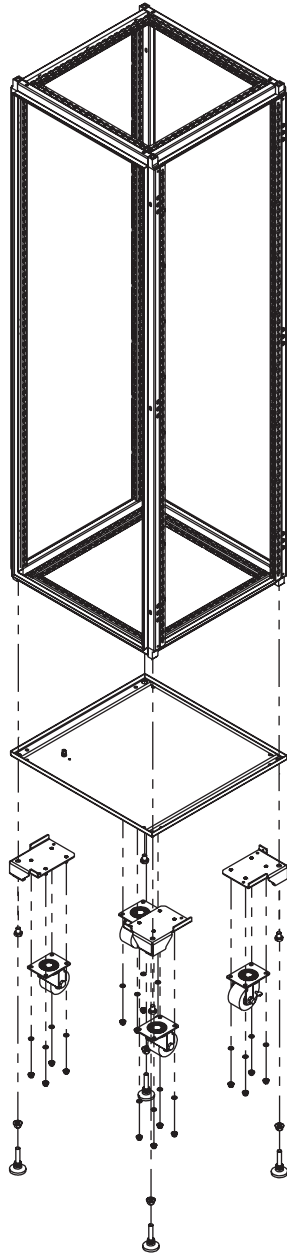

B

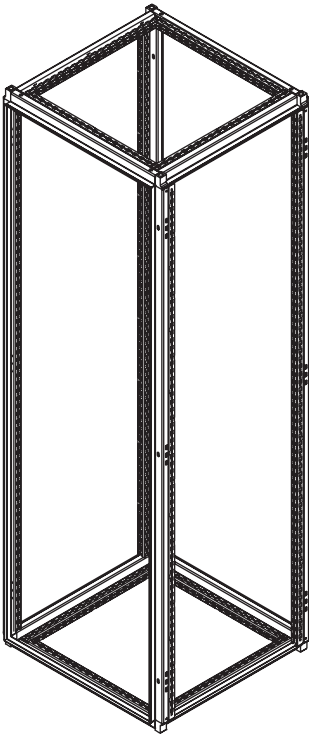

A

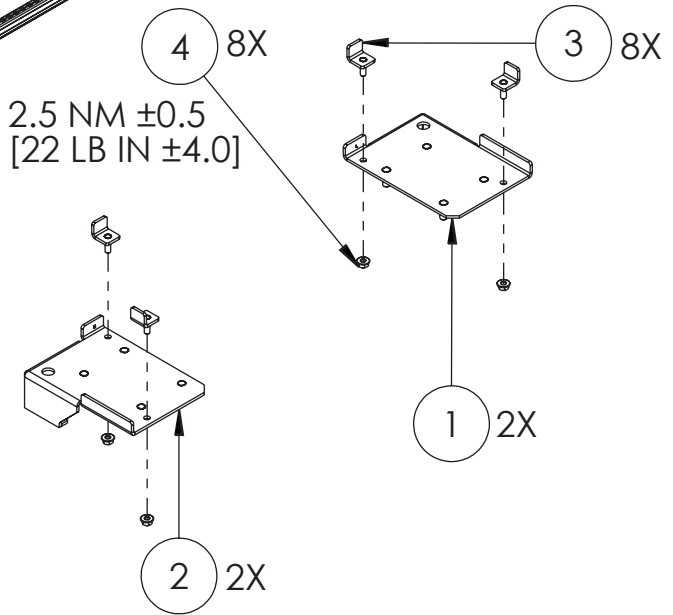

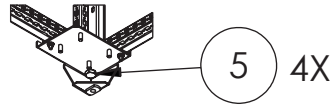
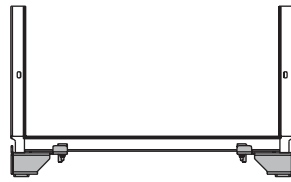

A

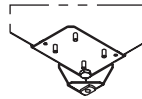
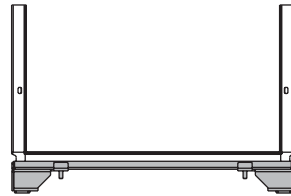

B

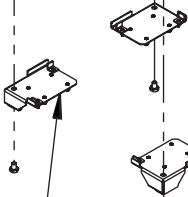
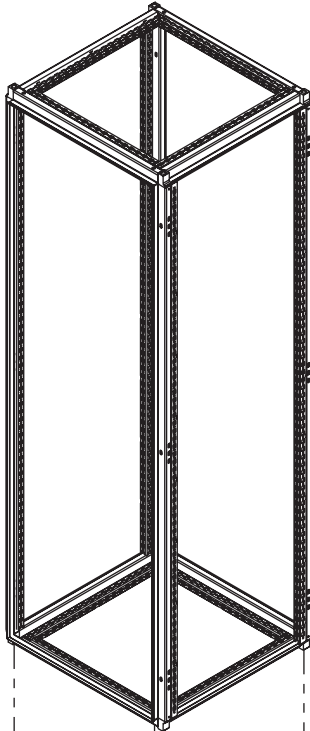

1 2X

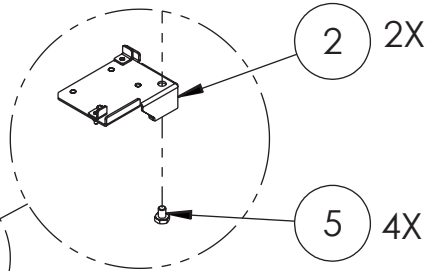

2 2X
5 4X
5.1 NM \pm 0.5
[45 LB IN \pm 4.0]

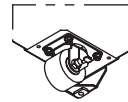
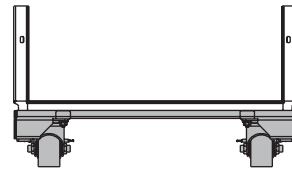
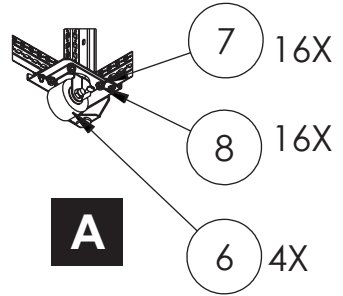
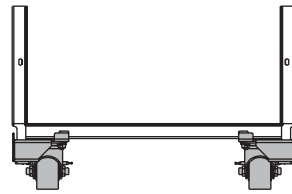
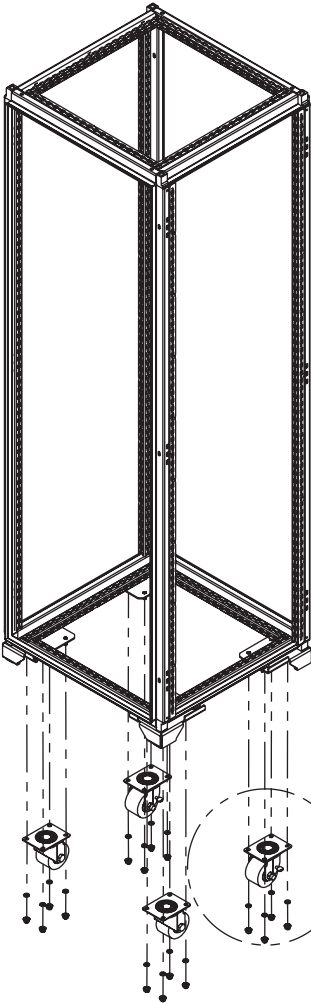

B

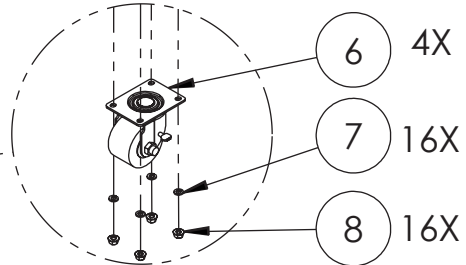

6.8 NM ±0.5
[60 LB IN ±4.0]

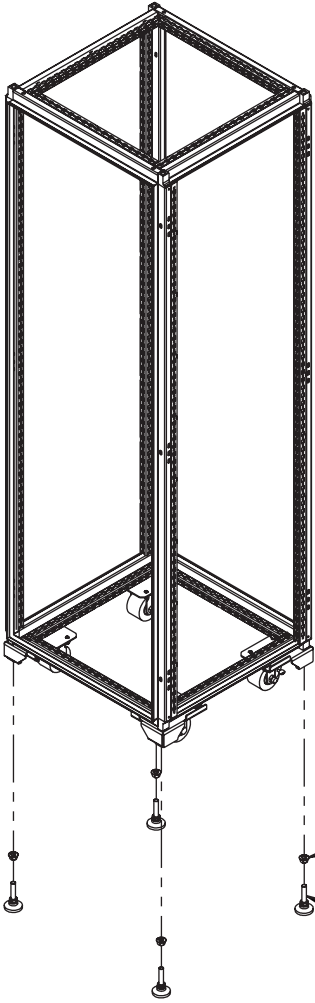

- 9 4X
- 10 4X

5.1 NM ±0.5
[45 LB IN ±4.0]

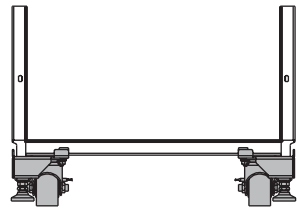

A

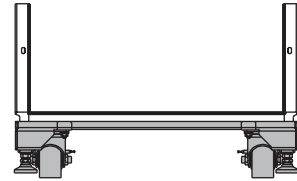

B

