

SYSPEND VHDS-MOTION ARM, TYPE 4X

INDUSTRY STANDARDS

Maintains NEMA Type 4, 4X and 12 and IEC IP 66 enclosure ratings when properly installed per Hoffman instructions.

APPLICATION

Heavy-duty, stainless steel vertical motion pendant arm provides corrosion resistance and suspends process and control equipment for easy cleaning. Operators in NEMA Type 4X environments can effortlessly lift, lower and reposition HMI enclosures using the pendant arm's field-adjustable counterbalance.

FEATURES

- Corrosion resistant stainless steel housing with provisions for water drainage from arm

- 26-in. arm supports loads of 45-125 lb. with 13-in. of vertical height adjustment
- 36-in. arm supports loads of 25-75 lb. with 20-in. of vertical height adjustment
- Field-adjustable gas spring counterbalance allows the user to adjust lifting force by turning an adjustment mechanism under the arm
- Angle of gas springs is adjustable (not the pressure); allows lifting force to be increased or decreased at any time for changes in load
- Tension adjustment at front of the arm provides additional fine-tuning of lifting force
- No locking enclosure handle required; enclosure stays in place when repositioned
- Easily interfaces with Hoffman HMI enclosures using a 60-x-60-mm enclosure mounting pattern (enclosure must be ordered separately; not for use with CS480 enclosures)
- 1.25-in. internal cable pathway maintains Type 4, 4X and 12 enclosure rating and protects wires and cables
- Gasketed mounting surfaces at both ends of arm maintain seal integrity
- Enclosure and arm can be swiveled 330 degrees with swivel stops available in 30-degree increments
- Standard models are available with machine-top mounting (wall-mount and post-mount adapters sold separately)
- Optional floorpost available

SPECIFICATIONS

- Type 304 stainless steel construction
- Gas spring counterbalance

BULLETIN: DBB, VM3

Catalog Number	Description	Wall-Mount Adapter	Post-Mount Adapter	Load Capacity (lb.)	Load Capacity (kg)	Arm Weight (lb.)	Arm Weight (kg)	K in./mm	S in./mm	T in./mm
VHDS26	VHDS-Motion Arm, 26-in. Machine-Top Mount	VHDSWALL	VHDSPOST	45-125	20-57	54	25	26.00 660	3.00 76	10.00 254
VHDS36	VHDS-Motion Arm, 36-in. Machine-Top Mount	VHDSWALL	VHDSPOST	25-75	11-37	60	27	36.00 914	4.00 102	16.00 406

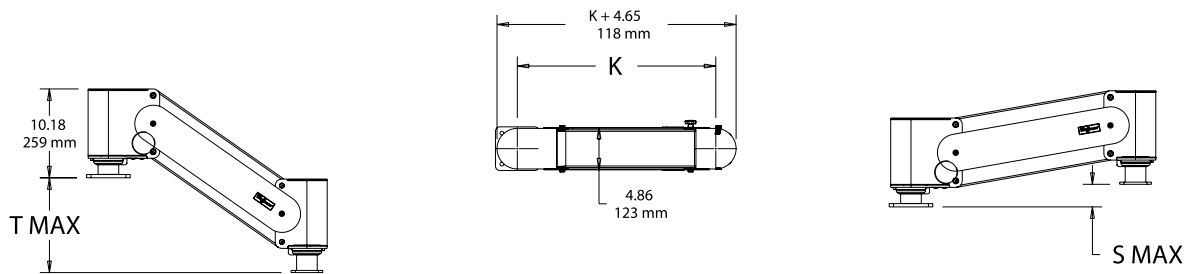

DOWNWARD TRAVEL

TOP VIEW

UPWARD TRAVEL

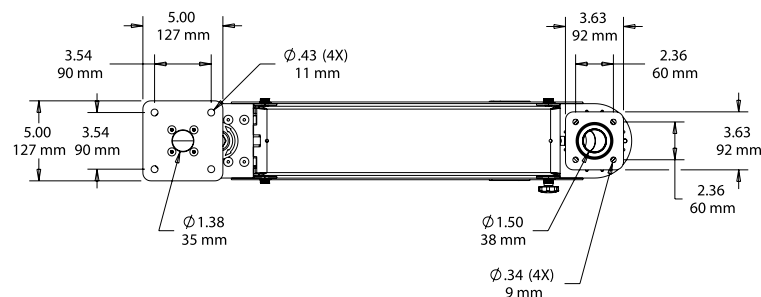

BOTTOM VIEW

87948608

WALL-MOUNT ADAPTER



Order separately to install the SYSPEND VHDS-Motion Arm on a wall or vertical surface.

- Type 304 stainless steel
- Includes hardware to mount the adapter to the arm
- Hardware for mounting to the wall is not included

BULLETIN: VM3

Catalog Number	Description	Weight (lb.)	Weight (kg)
VHDSWALL	VHDS-Motion Arm Wall-Mount Adapter	10.0	4.54

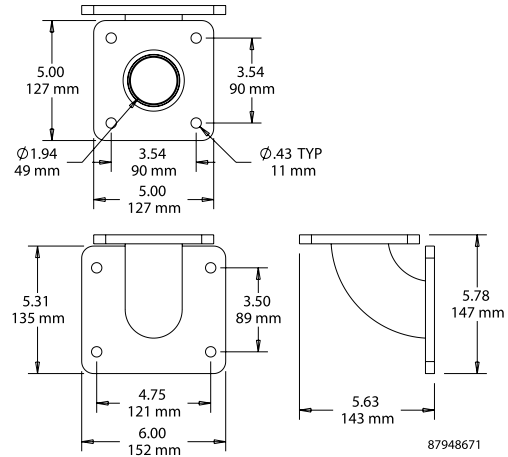

POST-MOUNT ADAPTER



Order separately when installing the SYSPEND VHDS-Motion Arm to a 3.5-in. OD tube.

- Type 304 stainless steel
- Includes hardware to mount the adapter to the arm and setscrews for mounting to a tube

BULLETIN: VM3

Catalog Number	Description	Weight (lb.)	Weight (kg)
VHDSPOST	VHDS-Motion Arm Post-Mount Adapter	7.0	3.18

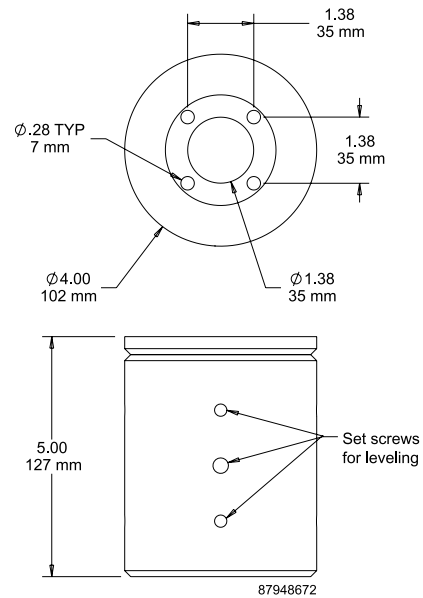

STAINLESS STEEL FLOORPOST WITH JUNCTION BOX



- Provides method for mounting the SYSPEND VHDS-Motion Arm when a structural surface is not available.
- Heavy-wall 3.5-in. structural tube welded to a 12 x 12 x 3/8-in.-thick baseplate
 - Provides a “rough-in” point and pull box for power and network field wiring
 - Includes internal CAT5 coupler and finger-safe power terminals
 - Two conduit knock-outs can be opened to either 1/2 in. or 3/4 in.
 - Fully gasketed 16 gauge cover panel on junction box can be used for additional conduit attachment
 - Tough, molded ABS junction box is contoured to fit the post and is fluted into the post to protect cables

BULLETIN: VM3

Catalog Number	Description	Weight (lb.)	Weight (kg)
FLOORPOSTSS	Stainless Steel Floorpost with Junction Box	70	31.75

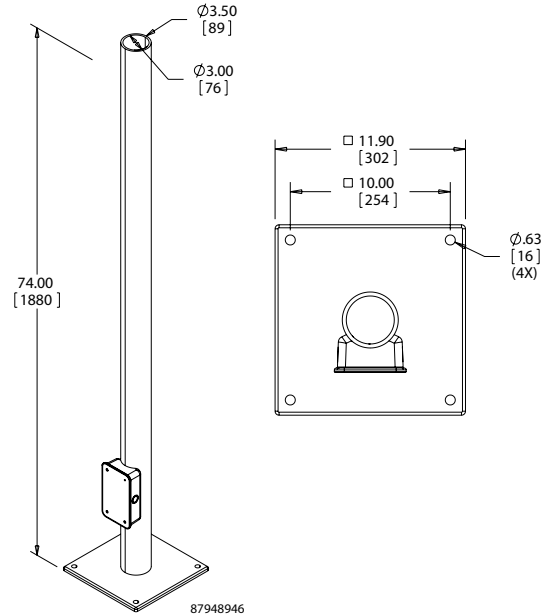

HANDLES



Handles are stainless steel for mounting on enclosure sides. Mounting hardware included. Enclosure machining required. (Handles are not required to use the SYSPEND VHDS-Motion Arm.)

BULLETIN: CCR6Y

Catalog Number	Description	Weight (lb.)
CCSSHDL	Handles for CC480/600 enclosures	5.0

Notes