

INSTALLATION INSTRUCTIONS

WET LOCATION EMERGENCY LIGHTING UNIT

with ROUND MR-16 TYPE LAMP HEADS

READ AND FOLLOW ALL SAFETY INSTRUCTIONS

CAUTION: The battery in this unit may not be fully charged. After electricity is connected to unit, let battery charge for at least 24 hours, then normal operation of this unit should take effect. To check, press TEST button. The emergency lamps should illuminate.

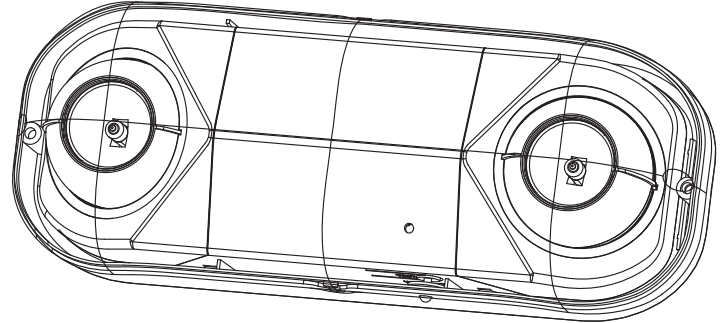

IMPORTANT SAFEGUARDS: When using electrical equipment, basic safety precautions should always be followed, including the following:

- Equipment should be mounted securely in locations and at heights where it will not be readily subjected to tampering by unauthorized personnel.
- Do not mount near gas or electric heaters.
- Cap unused wires with enclosed wire nuts or other approved method.
- Do not use this equipment for anything other than its intended use.
- May use outdoors (20°C/68°F -50°C/122°F)
- The use of accessory equipment not recommended by the manufacturer will void product listing and warranty and may cause an unsafe condition.
- Disconnect AC power before servicing and installation.
- Consult local building code for approved wiring and installation.
- Use caution when servicing batteries.
- Any service on this equipment should be performed by qualified personnel only.
- Make sure wire terminations are secure and leads are properly tucked in appropriate wire channels.

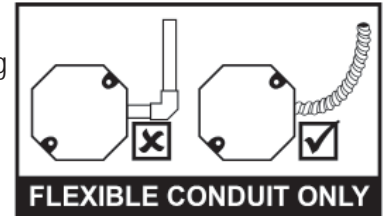

INSTALLATION:

NOTE: Max mounting height is 8 feet to achieve at least 1 ft-candle of illuminance in emergency mode.

1. Unscrew the polycarbonate cover from the front and pull the unit out.
2. Mount housing gasket and onto J-Box and secure with screws. Drill a hole on the back of the housing to pull the input wires out. Connect wires through J-Box.
3. Connect battery only after continuous AC power can be provided to the unit.
4. Place the unit back into the housing. Replace the polycarbonate cover and screw back on to the housing.
5. Apply continuous AC power. For 120V supply connect line wire to black lead; for 277V supply connect line wire to red lead. Connect neutral wire to white lead. Press "TEST" button to check for proper operation of the unit.

CAUTION: If conduit is applied, use UL Listed Suitable for Wet Location parts.

INSTALLATION INSTRUCTIONS

OPERATION:

1. Apply AC power to the unit. The LED Indicator should turn GREEN. If it shows RED, then it implies that the battery is disconnected or needs to be replaced.
2. After the battery has charged for 24 hours, test the unit by pushing the switch. The LED indicator turns OFF and the lamps on the unit turn ON.
3. When the switch is released, the lamps turn OFF and the LED indicator turns GREEN.

MAINTENANCE:

CAUTION: Always turn off AC power to the equipment before servicing. Service should be performed only by a qualified service technician. Use only manufacturer supplied replacement parts.

1. BATTERY: The battery supplied in this equipment requires no maintenance. However, it should be tested periodically (see TESTING) and replaced when it no longer operates the connected fixtures for the duration of a 30-second or 90-minute test.
2. OTHER: Clean lenses and replace lamps, as and when required.

TESTING:

National Electric Code (NEC) and NFPA Life Safety Code regulations require that routine tests need to be performed as listed below:

1. Once every month, the unit needs to be tested for duration of 30 seconds. Push in and hold the test switch to perform this test.
2. Once every 12 months, a full 90 minute (per UL requirements) test needs to be performed on the unit. Disconnect power to the unit and leave it in the emergency mode. The lamps should stay ON for at least 90 minutes.
3. Written records of the testing are to be kept for examination by the authority having jurisdiction.

TROUBLE - SHOOTING:

Condition - The emergency lights do not operate

1. If the charge indicator light is OFF: Check that the circuit breaker for AC supply is ON.
2. If the charge indicator light is ON: Check that battery is properly connected. If problem persists, Replace battery.

Condition - Emergency lights are dim

1. Battery not fully charged. Allow battery to recharge for 24 hours and then retest. If lights are still dim, replace battery.



An **Acuity** Brands Company

Lithonia Emergency

One Lithonia Way, Conyers GA 30012

Phone: 800-334-8694

www.lithonia.com

Part No. EMCSA00825 Rev. C

2017.06.20