

THIS COPY IS PROVIDED ON A RESTRICTED BASIS AND IS NOT TO BE USED IN ANY WAY DETRIMENTAL TO THE INTERESTS OF PANDUIT CORP.

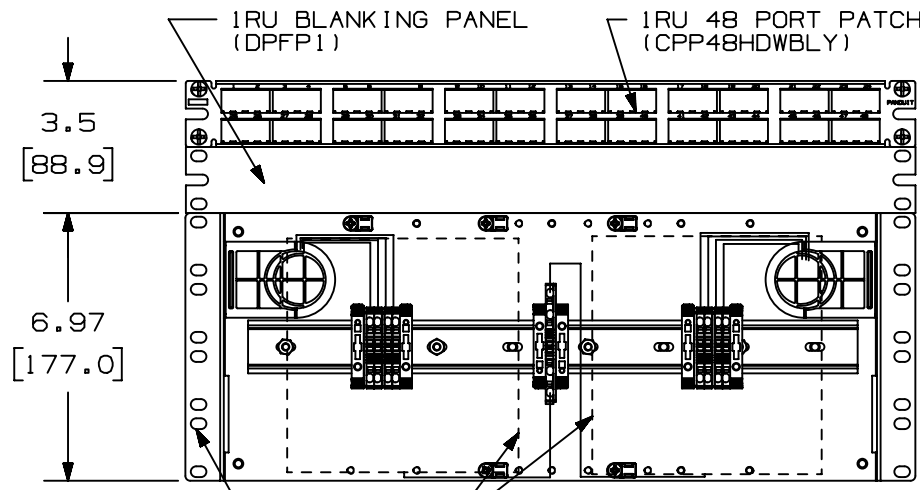

FRONT VIEW

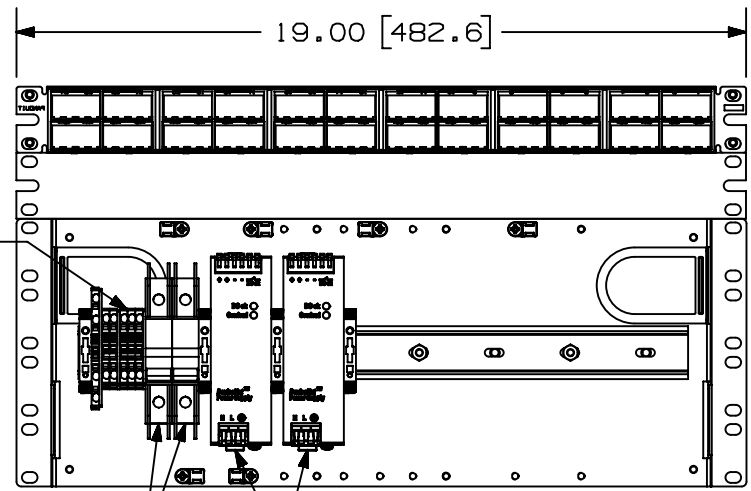

BACK VIEW

NOTES:

1. PART INCLUDES:
  - (1) DIN RAIL MOUNT BRACKET (IABDIN4)
  - (2) PULS 91.2W 24 VOLT DC POWER SUPPLIES (QS5.DNET)
  - (2) WEIDMULLER CIRCUIT BREAKERS (BR1D5UC)
  - (2) WEIDMULLER RED AND WHITE TERMINAL BLOCKS FOR INCOMING POWER (100-240 VAC 50-60HZ)
  - (1) 48 PORT PATCH PANEL (CPP48HDWBL)
  - (1) 1RU BLANKING PANEL (DPFP1)

RECOMMENDED TO IMPROVE THERMAL PERFORMANCE OF SWITCHES AND REDUCE UNINTENDED CONTACT WITH POWER SUPPLIES. IF NO SPACE IS AVAILABLE FOR THE BLANKING PANEL, MOVE THE PATCH PANEL DOWN 1RU TOWARD THE TIER.

  - (2) STRAIN RELIEF BARS (SRB19MDBL AND SRB19BLY) - (NOT SHOWN)
2. POWER CIRCUIT DESIGNED FOR UP TO (2) 24 VOLT DC INDUSTRIAL ETHERNET SWITCHES NOT TO EXCEED 42 WATTS PER SWITCH
3. COMPLIES WITH UL508A, WHEN INSTALLED PER PANDUIT INSTRUCTIONS
4. CLASS 2 POWER CIRCUITS ARE PRE-WIRED, LABELED, AND TESTED.

PART NUMBER		<b>ZDINS24</b>		
TITLE		<b>UNIVERSAL IDF, 100-240VAC IN, (2) 24VDC PS, HIGH DENSITY PATCH PANEL</b>		
ITEM REVISION NAME		CUSTOMER DRAWING		
DATASET FILE NAME		00157EDC/02		
MATERIAL		N/A		
DRAWING NUMBER		00157EDC-DC		
THIRD ANGLE PROJECTION				
DRAWN BY	DATE	CHK	SCALE	SIZE
RHG	4/16/18	EHA	NONE	A
SHEET 1 OF 2				

A-SIZE CUSTOMER

REV	DATE	BY	CHK	APR	DESCRIPTION	ECN
02A	2/7/22	JBO	MRWA	BETL	ADDED 1RU BLANKING PANEL ADDED DIM OF MAX AMOUNT OF SPACE FOR SWITCHES & MAX AIR GAP, SHEET 2	00157EDC
01A	1/4/19	EHA	JBO	KGA	INITIAL RELEASE	00157EDC

THIS COPY IS PROVIDED ON A RESTRICTED BASIS AND IS NOT TO BE USED IN ANY WAY DETRIMENTAL TO THE INTERESTS OF PANDUIT CORP.

WIRE HARNESS FROM POWER  
PASSES THROUGH THE GROMMET  
TO SWITCH MOUNTING LOCATIONS

TOP VIEW

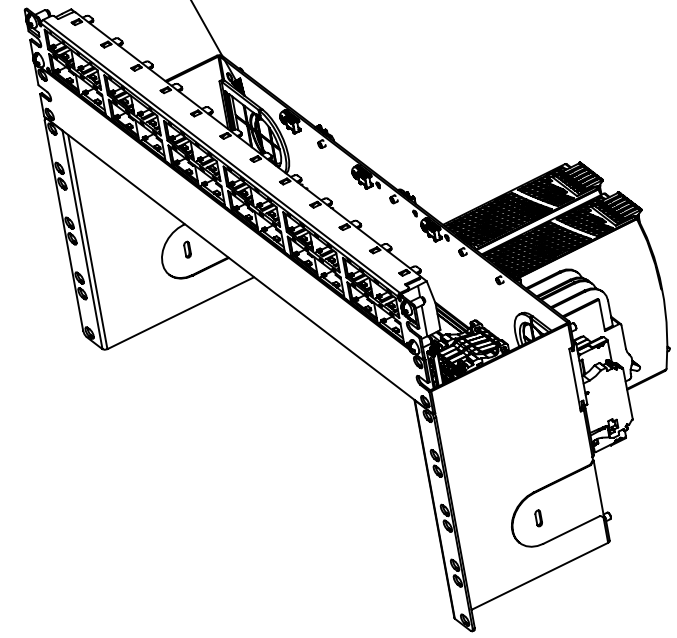
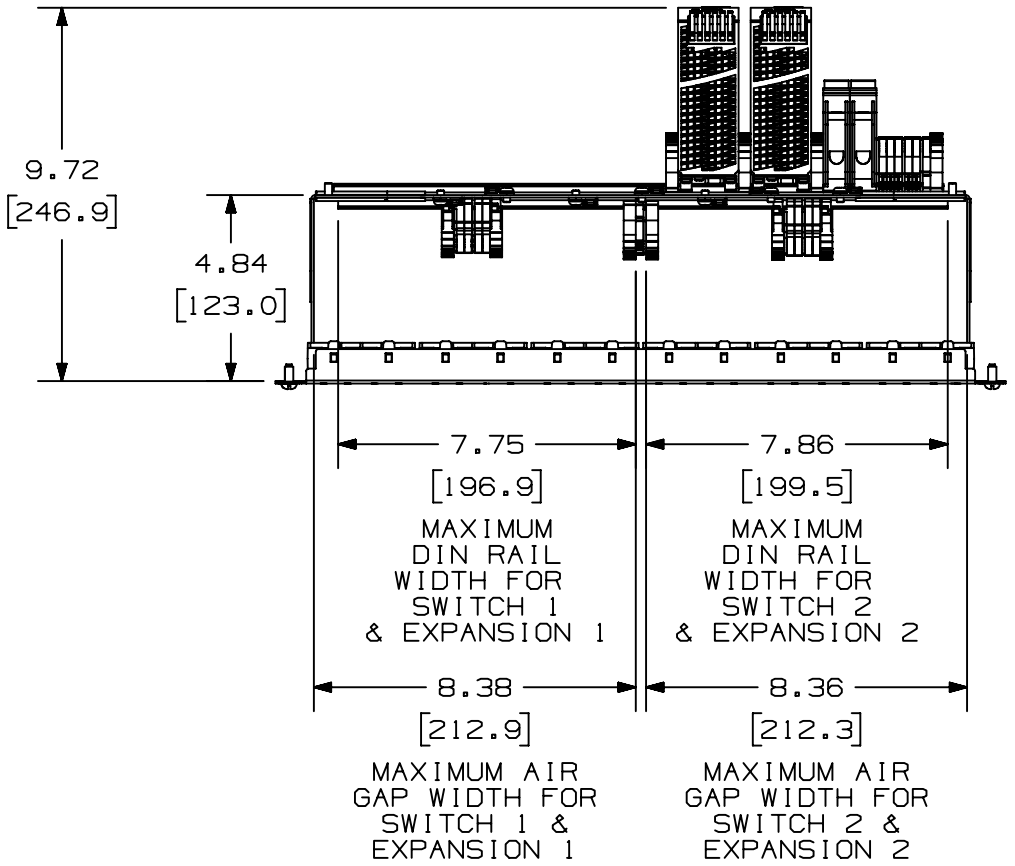

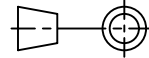
TITLE		UNIVERSAL IDF, 100-240VAC IN, (2) 24VDC PS, HIGH DENSITY PATCH PANEL		
		CUSTOMER DRAWING		
ITEM REVISION NAME		00157EDC/02		
DATASET FILE NAME		00157EDC_DC/02A		
		THIRD ANGLE PROJECTION		
MATERIAL		N/A		
		DRAWING NUMBER		
		00157EDC-DC		
DRAWN BY	DATE	CHK	SCALE	SIZE
RHG	4/16/18	EHA	NONE	A

A-SIZE CUSTOMER

02A	2/7/22	JBO	MRWA	BETL	REFER TO SHEET 1 FOR REVISION CONTROL	00157EDC
REV	DATE	BY	CHK	APR	DESCRIPTION	ECN